

4 SECTION  
1/2" = 1'-0"

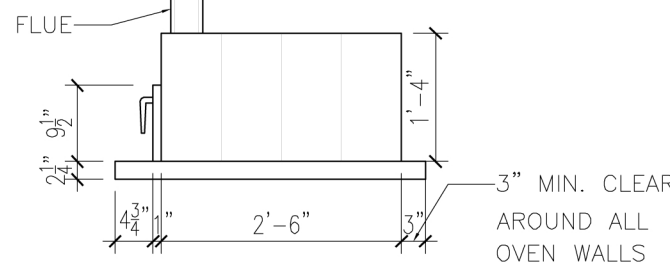

3 SIDE ELEVATION  
1/2" = 1'-0"

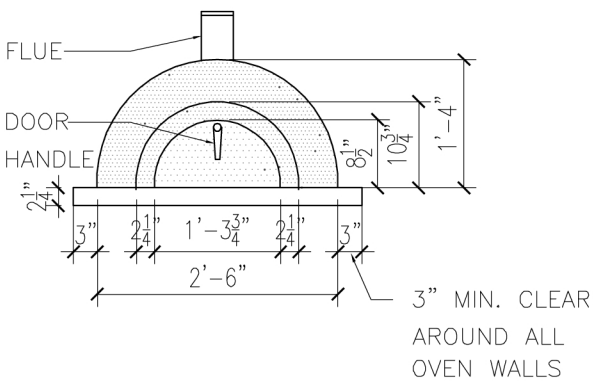

2 FRONT ELEVATION  
1/2" = 1'-0"

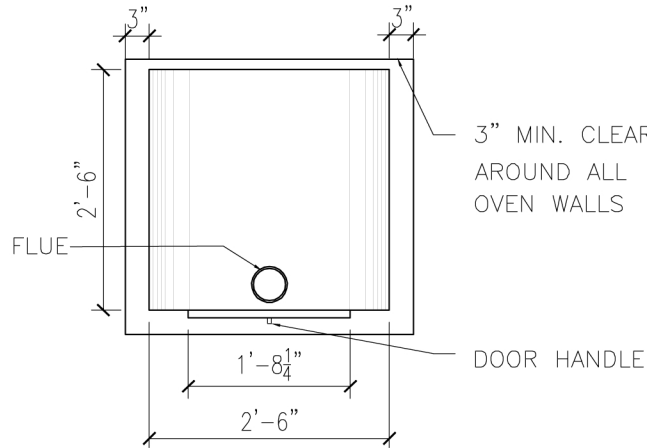

1 PLAN  
1/2" = 1'-0"

**GENERAL NOTES:**

THE CHIMNEY SYSTEM SHALL BE FACTORY BUILT, LABORATORY TESTED AND U.L. LISTED FOR THE FOLLOWING STANDARDS AND CODES:

1. UL103 STANDARD FOR CHIMNEYS, FACTORY-BUILT, RESIDENTIAL TYPE AND BUILDING HEATING APPLIANCE WITH THE FOLLOWING TEST CONFIGURATIONS MAY BE FULLY ENCLOSED IN COMBUSTIBLE CONSTRUCTION WHEN INSTALLED IN ACCORDANCE WITH MANUFACTURERS INSTALLATION INSTRUCTIONS 1000°F CONTINUOUS FLUE GAS TEMPERATURES 2100°F FOR 10 MINUTES, SIMULATING A CHIMNEY FIRENFPA 211 STANDARD FOR CHIMNEYS, FIREPLACES, VENTS, AND SOLID FUEL-BURNING APPLIANCES THE CHIMNEY SHALL HAVE AN INNER LINER OF 304 STAINLESS STEEL CONSTRUCTION, SURROUNDED BY 1" FIBER INSULATION, AND GALVANIZED OR STAINLESS STEEL OUTER JACKET.

**SPECIFIC NOTES:**

NOTE: 430 STAINLESS STEEL INNER LINERS ARE NOT RECOMMENDED AND HAVE VERY LIMITED WARRANTIES. THE CHIMNEY SHALL BE SIZED IN ACCORDANCE WITH CURRENT ASHRAE GUIDELINES, OR OTHER APPROVED ENGINEERING METHODS. THE CHIMNEY SYSTEM SHALL BE COMPLETE WITH ALL NECESSARY COMPONENTS FOR INSTALLATION INCLUDING TRANSITION TO OVEN, SUPPORTS, ADJUSTABLE ELBOWS, FIRESTOPS, CLEANOUTS, ROOF PENETRATIONS, AND FLUE TERMINATIONS AS REQUIRED BY MANUFACTURERS' INSTALLATION INSTRUCTIONS. TO OBTAIN PREPARED SHOP DRAWINGS AND CHIMNEY SIZING DATA CONFIRMING WITH ALL OF THE ABOVE VENTING REQUIREMENTS, SIMPLY CONTACT PRECISION VENT, INC. OR MECHANICAL SALES CO. AT 678-461-5997 OR EMAIL THAD@B-VENT.COM WWW.PRECISIONVENT.COM.

DESCRIPTION		ROMA-2	
DATE	12-05-05	REV	
SCALE	1/4"=1'-0"	SHEET	A1