

America's Heat

OWNERS MANUAL

Model AH-100 Furnace -100,000 Btu

Model AH-170 Furnace -170,000 Btu



LMF MANUFACTURING

Manufacturing Facility
900 Park Avenue
Woolrich, PA 17779
(570) 769-7775

THE AMERICAS HEAT FURNACES

February 2010

Congratulations on your purchase of an Americas Heat Biomass/Corn furnace. The 100,000 BTU model was the first biomass furnace to be listed by Underwriters Laboratories. The U.L. listing is your assurance of a safe and quality product. In 2006, we introduced the 170,000 BTU model.

As convenient fuels become more expensive and less abundant, biomass fuels become a very attractive and viable alternative heat source. In these times of high energy costs, it makes sense to use a heat source that utilizes a resource that is readily available and cost effective.

LMF Manufacturing believes that there is no substitute for safety and quality. You can place confidence in that your Americas Heat Furnace will serve your heating needs now, and for years to come. We ask that you follow our policy of... "safety first" when installing and using your Americas Heat furnaces. We strongly advise you to read the owners manual before installing and operating your furnace.

Your Americas Heat furnace is a viable alternative heat source specifically designed for residential and small commercial applications. Proper care of this appliance should result in many years of service and comfort. An annual checkup by a competent service technician is recommended.

If you have any problems, questions, or concerns, please contact your nearest Americas Heat dealer or contact LMF Manufacturing Co., Tech Center, located at 900 Park Ave., Woolrich, PA 17779. Tel No: 570-769-7775. Please furnish the Americas Heat serial number, which is located on the front panel of the furnace.

PLEASE READ ALL INFORMATION ON THIS PAGE BEFORE INSTALLATION

1. This appliance must be installed in accordance with local codes.
2. Installation is to be performed by a qualified installer, according to federal, state and local codes.
3. Maintain adequate minimum clearances to combustible materials. (See page 5)
4. Install in an area with adequate air for combustion and ventilation - 60 cubic feet per minute (cfm) minimum.
5. Do not connect this unit to a chimney flue serving another appliance.
6. Disconnect all power to the unit before performing routine maintenance or service. Before servicing, allow the furnace to cool.
7. Establish a regular service and maintenance schedule for efficient and safe operation. Have a qualified service person perform tasks you are not familiar with.
8. Caution: Children and adults should be alerted to the potentially high surface temperatures of the burner door. Keep children away!
9. Danger: Risk of fire or explosion. Do NOT burn gasoline, oil, garbage, or other flammables in this appliance.
10. Do not place clothing or other flammable materials on or near this appliance.
11. Ashes should be placed in a metal container with a tight fitting lid. The closed container of ashes should be placed on a non-combustible floor or on the ground, well away from all combustible materials pending final disposal. If the ashes are disposed of by burial in soil or otherwise dispersed, they should be retained in the closed container unit until all clinkers have thoroughly cooled.
12. Use only U.L. approved furnace filters. (Filters included)

UNPACKING AND SET UP

1. After removal of shipping materials, remove the furnace from the pallet by removing the three shipping screws securing the furnace to the pallet. One (1) screw is accessible by removing the filter door. The remaining two (2) are removed from under the pallet. Remove auger motor assembly and furnace assembly package from Burn Pot door.

Furnace Assembly Package includes:

1-Fuel Delivery Coupler
1 - Self Tapping Bolt
3 - Wire Nut connectors

1-Barometric Draft Control
1- Hopper Hardware Bag
2- Wooden Handles

2. Insert burner auger assembly into burner auger tube and secure assembly with self tapping bolt using hole provided in burner auger tube. (See Figure 1).
3. Remove cover from auger motor. Fasten flex conduit extending from the electrical box to furnace auger motor housing using conduit lock nut. (See Figure 1) See Step 4 under storage bin set up for wiring procedures.
4. Slide wooden handles on door handle and heat exchanger.



STORAGE BIN

1. After removal of shipping container, position storage bin on storage bin base, at desired angle for installation. For bolt together - fabricated metal hopper stand, see page 16.
2. Install auger assembly by sliding auger boot (with clamp) over bin outlet; align elbow on bin auger tube directly over furnace fuel inlet. Tighten auger boot clamp securely. It is advisable to install two sheet metal screws (not supplied) thru the clamp, auger boot, and into the hopper bin outlet to insure a permanent connection. Install fuel delivery coupler between bin auger tube and furnace fuel inlet.
3. Fasten flex conduit extending from storage bin auger assembly to furnace auger motor housing using conduit lock nut.
4. Connect one black auger motor lead to the two orange wires with wire nut connector. Connect the other black auger motor lead to the two white wires using wire nut connector. (See Figure 1)

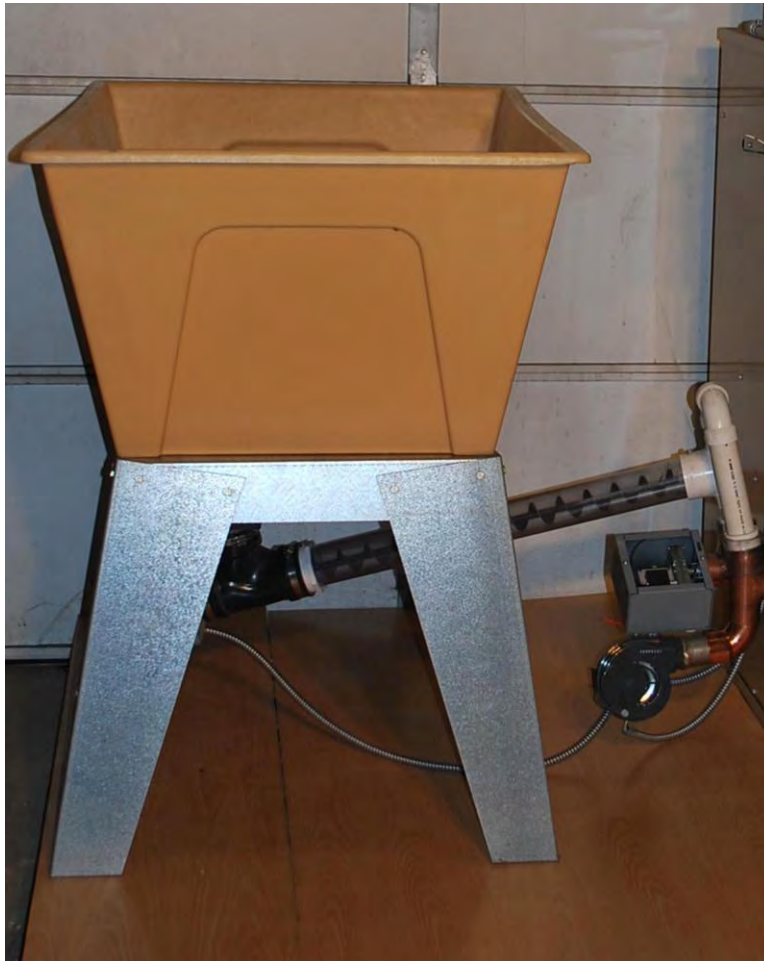

INSTALLATION

WARNING-FAILURE TO INSTALL THE AMERICAS HEAT FURNACE ACCORDING TO INSTRUCTIONS MAY VOID THE WARRANTY.

Install the Americas Heat furnace in a room with adequate air for combustion and ventilation – 60 cubic feet per minute minimum. Minimum clearances for the Americas Heat furnace is 32" from top of furnace to ceiling, 30" from the front of the furnace to the wall, 6" on either side and 18" from the back of the furnace to the wall.

The Americas Heat furnace is for use as a primary heat source. The Americas Heat furnace should be installed with the metal hot air plenum connected to metal hot air duct work and metal cold air return plenum joined to return air system. This unit is not designed to be installed as an ad-on furnace. If you plan to use the Americas Heat furnace in conjunction with another furnace, install safety measures to prevent air back feed from one furnace to the other. Failure to take this precaution could cause either furnace to overheat.

****IMPORTANT**** Maintain the 14" x 14" (196 sq. in.) hot air and return air connections to your existing duct work. Reduction in size of these connections can restrict air movement over and thru the heat exchanger, resulting in overheating and operational problems with the furnace.

Connect the Americas Heat furnace to a lined masonry chimney acceptable to the authority having jurisdiction. USA installation may also use a residential type and building heating appliance chimney. Canadian installation may also use a 6" (minimum) metal flue pipe using sheet metal screws. Do not connect the furnace to any chimney flue servicing any other heating appliance, as recommended by the Nation Fire Prevention Association. All chimney connections must meet the approval of the local building inspector and fire marshall and conform to all local, state, provincial and national codes.

****IMPORTANT**** The following procedure for measuring and setting the proper chimney draft is probably the most important installation procedure to follow for the proper operation of the Americas Heat furnace.

The Americas Heat furnace requires .02- .04 in. water column draft (chimney draft) on low fire, to assure proper operation. Low fire mode is when the thermostat is satisfied and fuel is not being augered into the burner. When the chimney draft is too high, burner fire may go out. If the chimney draft is too low, smoke may back up in the furnace and storage bin, causing a possible hazard.

The supplied barometric regulator should be installed in the flue (as per the enclosed instructions) to properly regulate .02- .04 inc. water column draft. The counter weight setting on the barometric regulator regulates this setting. (See "ADJUSTING THE CONTROL" instructions below.)

If the chimney draft should never exceed .04 in. water column. On extremely tall chimneys or on chimneys larger than 6" diameter, it may be necessary to install a 2nd barometric regulator or to reduce the outlet opening on the chimney to approximately 28 square inches or both to maintain the required .02 - .04 in. water column draft.

The Americas Heat furnace can be installed on a combustible floor if a non-combustible material is placed directly under the ash removal door and chimney connector. The mat is to extend at least 16" in front of and 8" to each side of the ash removal drawer and 2" either side of the chimney connector.

Fig. 1

INSTRUCTIONS FOR INSTALLING FIELD

TYPE R-C

BAROMETRIC DRAFT CONTROLS

INSTALLATION AND ADJUSTMENT — See sections on control locations and collar installation.

Insert the draft control into the collar. The front face of the control **must be plumb**. The bearing surface **must be level** whether the control is on a horizontal, vertical, or sloping flue pipe. Use a spirit level, plumb and level accurately. Secure the control in the collar by tightening the clamping screws. If the collar is not supplied by Field, the control may be held in place by small bolts or sheet metal screws so located as not to interfere with the movement of the gate.

VERTICAL FLUES — The control is shipped for installation in a vertical flue. The adjustment weight should be in the right hand slot when you face the control. See Figure 2.

HORIZONTAL FLUES — For horizontal flues, remove the weight from the right hand slot and attach it to the left hand slot as shown in Figure 2.

CONTROL LOCATIONS — The control should be located as close as possible to a furnace or boiler and positioned as shown in Figure 1. It should be 18" from a stack switch and at least 18" from a combustible ceiling or wall. Do not locate in a room separated from the appliance.

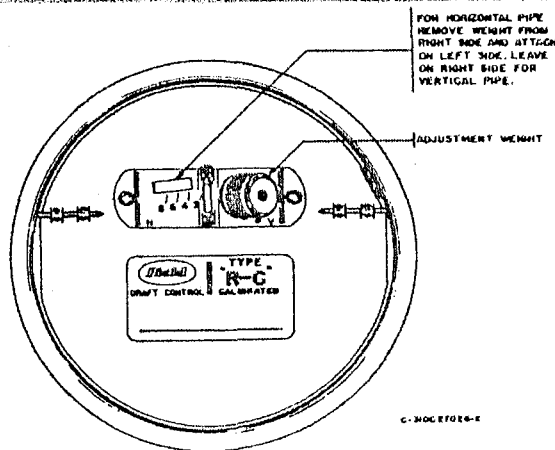

Fig. 2

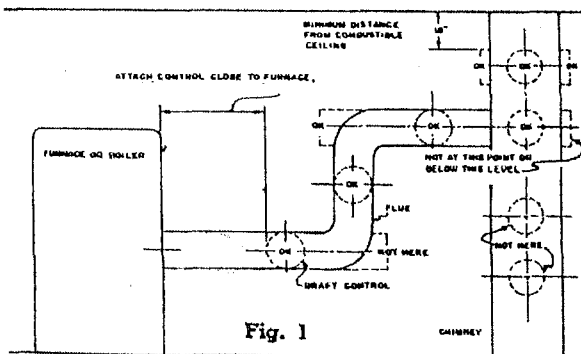

Fig. 1

ADJUSTING THE CONTROL — Set the control to maintain as low a draft as will give good combustion and meet the requirements for heat. Turn the adjustment weight counter-clockwise to loosen, then slide in slot to the proper position and tighten. The bracket is marked 2, 4, 6 and 8, which indicates draft settings of .02", .04", etc. (These are drafts in flue adjacent to control, not over-fire drafts.)

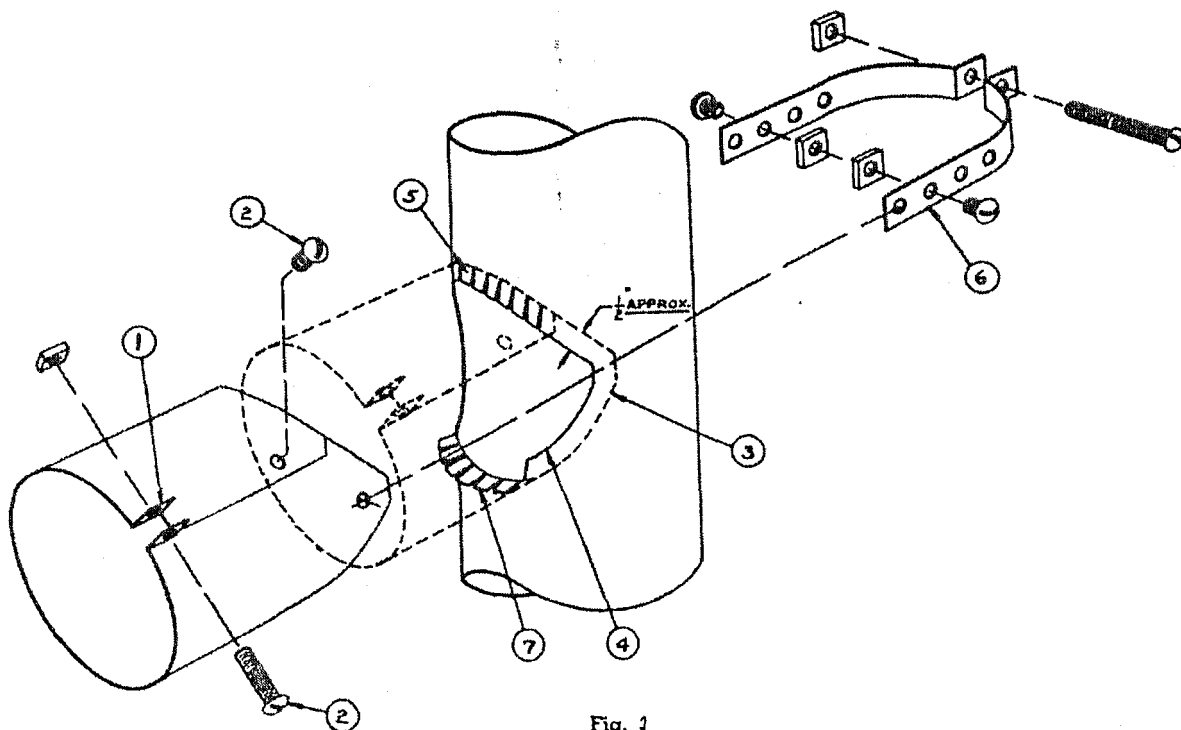

Fig. 1

COLLAR INSTALLATION — This control is shipped with a collar prealtered to fit a round breeching. To attach this collar to the flue, see figure 3 and follow the instructions as follows:

1. Bend outward the two ears at the front corners of the collar. Bend 90°, 1/4 inch behind the single hole on the straps.
2. Insert clamping screw in ears on collar and bolt the remainder of the collar together.
3. Hold the collar against the side of the flue in the exact position it is to be installed (shown by dotted lines) and mark the outline of the collar on the flue.
4. Cut a hole in the flue about 1/2" inside of this outline.

5. Make a series of cuts about 1/2" apart from the edge of this hole to the outline marks.
6. Strap the collar to the flue pipe.
7. Bend the tabs formed by the series of cuts outward against the inside of the collar to make a tight joint.
8. Insert the draft control (See Installation & Adjustment).

If flue pipe is made of material too heavy to bend out into collar, make the diameter of the opening within 1/4" of the inside diameter of the collar.

THERMOSTAT WIRING

Connect thermostat wires to "R" and "G" terminals located on the relay, mounted on the furnace control box. Note: There is also a "C" terminal on the relay. Positively identify these terminals before connecting the thermostat wire. Connecting a thermostat wire to the "C" terminal will permanently damage the relay. The location of the thermostat has an important effect on the operation of your furnace. Be sure to follow the instructions included with your thermostat.

ELECTRICAL WIRING

WARNING: For your personal safety, turn off electrical power at service entrance before making any electrical connections.

All electrical work must conform to your local codes and ordinances or with the National Electrical Code. If you are not familiar with wiring and codes in general, have a competent electrician do this job.

Make connections to the furnace junction box from a 120v, 15 amp fused circuit; black to black, white to white and ground to ground terminal located inside junction box. Solder and tape or use wire nuts on all connections.

BURNER LIGHTING

1. Add dry, (14%-15% moisture) clean USDA #3 or better) corn or pellets to holding bin. (See "Important" below) CAUTION: corn or pellets with stalks, excess cob, fines, dirt, etc. may cause the augers to plug resulting in excessive wear and possible auger motor failure. Burning treated seed corn is not suggested because of excessive clinker build up and problems with fire extinguishing, caused by the treatment used on the corn.

****IMPORTANT**** Use of powdered graphite: On the initial lighting of the furnace, add only approx. 2-3 cups of corn to the hopper, then add approx. 4-5 tablespoons of powdered graphite. Continue with steps 2 thru 7. As the corn and graphite feeds into the hopper auger, repeat this procedure two more times. The powdered graphite will lubricate the hopper auger until it begins to polish from the flow of the corn or pellets. This procedure should be followed at the beginning of each heating season. This procedure should also be followed if the hopper is allowed to empty and the resulting sticky smoke film coats the hopper feed auger. Powdered graphite may also be added once a month at a time when the hopper is low on fuel, to help keep the auger lubricated and polished.

2. Turn on the electric power to the furnace.
3. Turn thermostat to highest setting.
4. Fill burner with corn or wood pellets to the lower set of air holes located on the inside of the burner.
5. Liberally fill burner to the top with kindling wood and paper, light paper and close the door. NOTE: Gelled fire starter may be used as a substitute.
6. Depress switch to start position. This will activate the combustion blower only. Continue to depress switch to start position for three to five minutes or until auger motors are activated. (Fuel will not begin to auger until furnace has reached operating temperature and auger motors are activated.)
7. Turn switch to "ON" position.
8. Set wall thermostat to temperature desired.
9. It may be necessary to add kindling wood a couple of times before the corn is completely ignited.

NOTE: If the burner has been used, all leftover ash and clinkers must be thoroughly removed from the burner before lighting instructions above.

OPERATION

After the burner has been lit and operating temperature has been reached (See burner lighting page 8) you need only to set the thermostat to the desired temperature. The thermostat will turn the furnace bin auger motors and combustion blower, on and off, to sustain the desired temperature.

A typical furnace cycle would be:

1. Thermostat activates fuel feed system, feeding the burner with fuel. (HIGH FIRE).
2. Heat builds up in the furnace activating the fan switch, which in turn starts the furnace blower.

NOTE:

The furnace blower on the Model 620-9 has (3) speeds. Low (red wire #3), Medium (blue wire #2) & High (black wire #1) The AH-100 is shipped from the factory on the Medium speed. Blower speed may be changed by accessing the 4 in. x 4 in. electrical junction box on the side of the furnace. Change blower speeds by disconnecting the yellow furnace wire from the current speed wire and reconnecting it to the desired speed wire. Disconnected lead must be insulated using the wire nut removed from desired speed wire.

The furnace blower on the AH 170 has (4) speeds. High (Black wire); Medium High (yellow wire); Medium low (Orange wire); Low (red wire) Blower speed can be changed by accessing the other wires behind the left side air filter. Disconnect the black to black wire and reconnect to the desired colored wire using existing wire nut.

3. When the thermostat setting is satisfied, the thermostat will shut off the fuel feed system.
4. The furnace timer will activate the auger and dispense a specified amount of corn to sustain burner fire. (LOW FIRE) Timer is factory set at two (2) minutes ON and six (6) minutes OFF. (This is a suggested setting - actual setting can be varied with user experience.)
5. Furnace blower will continue to run until heat is removed from furnace, then turns off.

CLINKER BUILDUP

The AmericasHeat furnaces feed corn into the bottom of the burner, therefore creating the most efficient fuel CONSUMPTION. The residual ash and clinkers are then spilled over the top of the burner ring, falling into the ash pan below. This process essentially cleans the burner chamber.

CAUTION: If the furnace is installed in an unsuitable application, causing the furnace to run on high fire for extended amounts of time, clinkers can form resulting in furnace inefficiency.

The clinkers that stick to the side of the firepot must be loosened with a furnace poker (provided) and are moved manually with furnace tongs or the clinkers could render the furnace inoperative.

INITIAL SETTINGS

See Automation Correct Corn-trol Manual.

Thermostat is preset at factory according to the model and auger motors. The AH-170 can be set to run at a lower btu with an adjustment to the thermostat settings.

MAINTENANCE

Daily

1. Inspect burner. Clinkers will be pushed out of the top of the burner as fuel is augered into the burner. Clinkers that appear to be stuck to the side of the burner should be wiggled loose. Large clinkers that may appear must be manually pushed over the top of the burner with a furnace poker or equivalent tool.
2. Check corn or pellet level in holding bin for adequate supply.

Weekly

1. Check contents of ash drawer and empty as needed. Ashes should be placed in a metal container with a tightly fitting lid. The closed container ashes should be placed on a non-combustible floor or on the ground, well away from combustible materials pending final disposal.
2. Pull flue scraper all the way out and push back in, this maintains the efficiency by removing ash from the heat exchanger tubes.
3. Check filters.

Monthly

1. Replace filters.

Annually

***** IMPORTANT *****

1. Remove and inspect all chimney pipe connections; clean out ash build up.
2. Clean, oil, and inspect all blower and auger motors.

SUMMARY OF SETTINGS & OPERATION

HIGH FIRE

Adjustment of the opening on the combustion blower inlet controls fuel air mixture on high fire only. This opening should be adjusted during the high fire mode of operation to obtain an intense flame that consumes the fuel at the same rate it is augured in.

LOW FIRE

Adjustment of the chimney draft controls the rate of burn on the low fire mode of operation. Chimney draft must remain below .04 inches W.C. and constant. The use of a second automatic barometric damper may be necessary on some installations to insure the precise draft control. A setting of .02- .03 is ideal. In most installations, the counter weight on the automatic barometric dampers should be set on the minimum setting. Adjusting the on and off cycle time settings on the low fire timer controls the amount of fuel fed to the firepot during the low fire mode of operation. The initial setting of this low fire timer is "6 minutes OFF" and "2 minutes ON". After approximately 24 hours of operation, a layer of ashes and clinkers form in the combustion area. After this layer of ash and clinkers form, the OFF time can be increased to reduce the amount of fuel consumed during this "low fire" mode of operation. The low fire timer is located inside the electrical box where the On/Off toggle switch is located.

REPAIR PARTS

Cabinet

Model BM 620-9

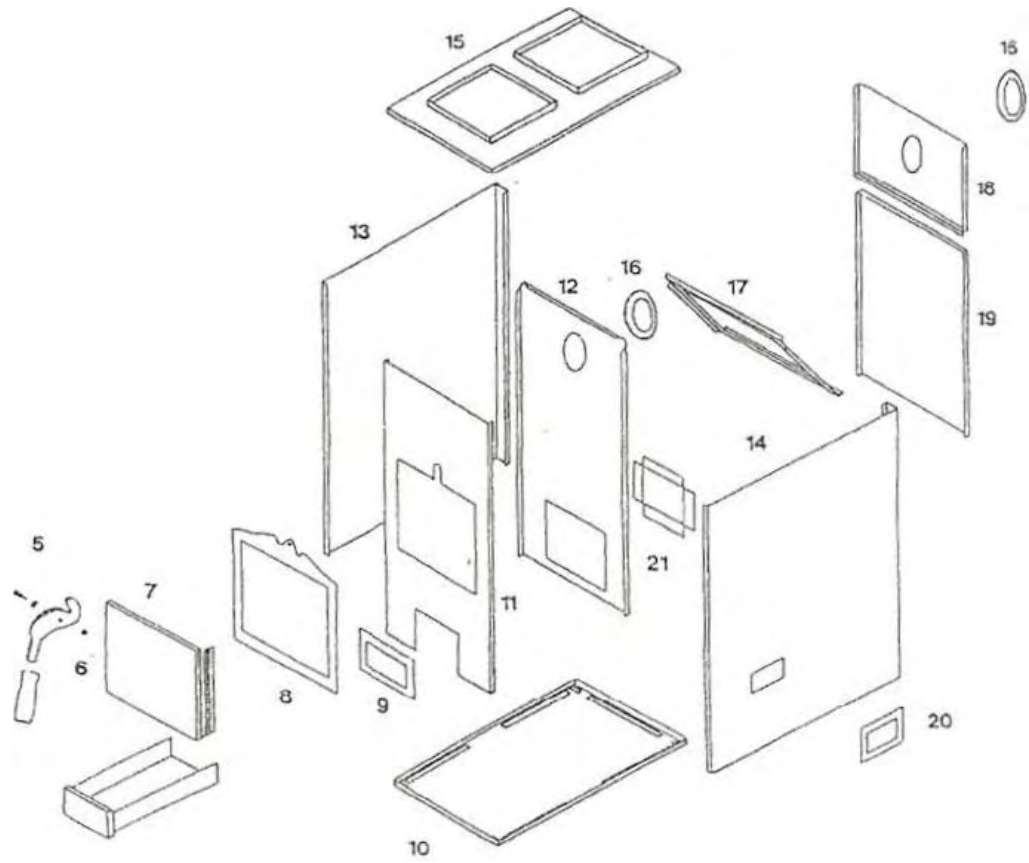

Model BM620-9

REPAIR PARTS

KEY#	PARTNUMBER	PARTDESCRIPTION
1	A-4040	ASH PAN
2	2200	WOODEN HANDLE
3	2220	DOOR HANDLE
4	1960	5/16" X318" SHOLDER BOLT
5	2000	5116" LOCK WASHER
	2020	1/4" NUT
7	A-4180	BURNER DOOR
8	6460	DOOR TRIM
9	6440	ASH DRAWER TRIM
10	A-6040	FURNACE FLOOR
11	6220	FRONT PANEL
12	6200	COLD AIR WALL
13	6280	LEFT SIDE PANEL (LEFT OR RIGHT HANDED FURNACE)
14	6240	RIGHT SIDE PANEL (AUGER HOLE ON THE RIGHT SIDE)
	6260	LEFT SIDE PANEL (AUGER HOLE ON THE LEFT SIDE)
15	A-61B	FURNACE TOP
16	6400	TRIM RING
17	A-4260	FILTER RACK
18	6300	TOP REAR PANEL
19	A-6340	FILTER ACCESS DOOR
20	6420	AUGER HOLE TRIM
21	2180	2" X 1/8" GASKET TAPE

REPAIR PARTS

Model AH-170

Cabinet

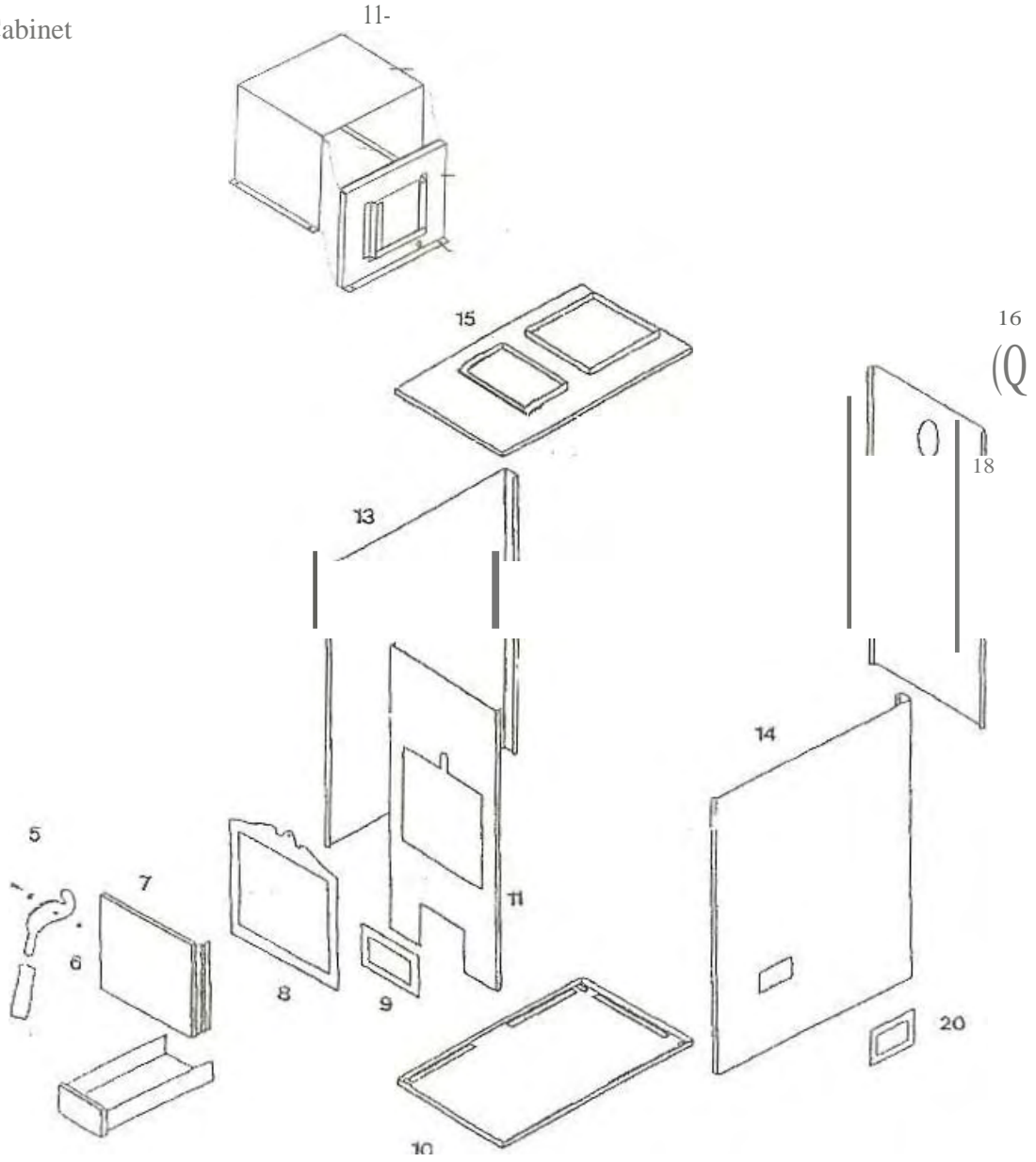

Model AH 170

REPAIR PARTS

KEY#	PART NUMBER	PART DESCRIPTION
1	A-4040	ASH PAN
2	2200	WOODEN HANDLE
3	2220	DOOR HANDLE
4	1960	5/16 X 3/8" SHOULDER BOLT
5	2000	5/16" LOCK WASHER
6	2020	1/4" NUT
7	A-4180	BURNER DOOR
8	6460	DOOR TRIM
9	6440	ASH DRAWER TRIM
10	A-6040	FURNACE FLOOR
11	6220	FRONT PANEL
12	5050170	BLOWER HOUSING
13	6280170	BLANK SIDE PANEL (LEFT OR RIGHT HANDED FURNACE)
14	6240	RIGHT SIDE PANEL (AUGER HOLE ON THE RIGHT SIDE)
15	6260170	LEFT SIDE PANEL (AUGER HOLE ON THE LEFT SIDE)
16	6160170	UPPER FURNACE TOP
17	6400	TRIM RING
18	3030170	REAR PANEL
19	6420	AUGER HOLE TRIM

-Heat Exchanger

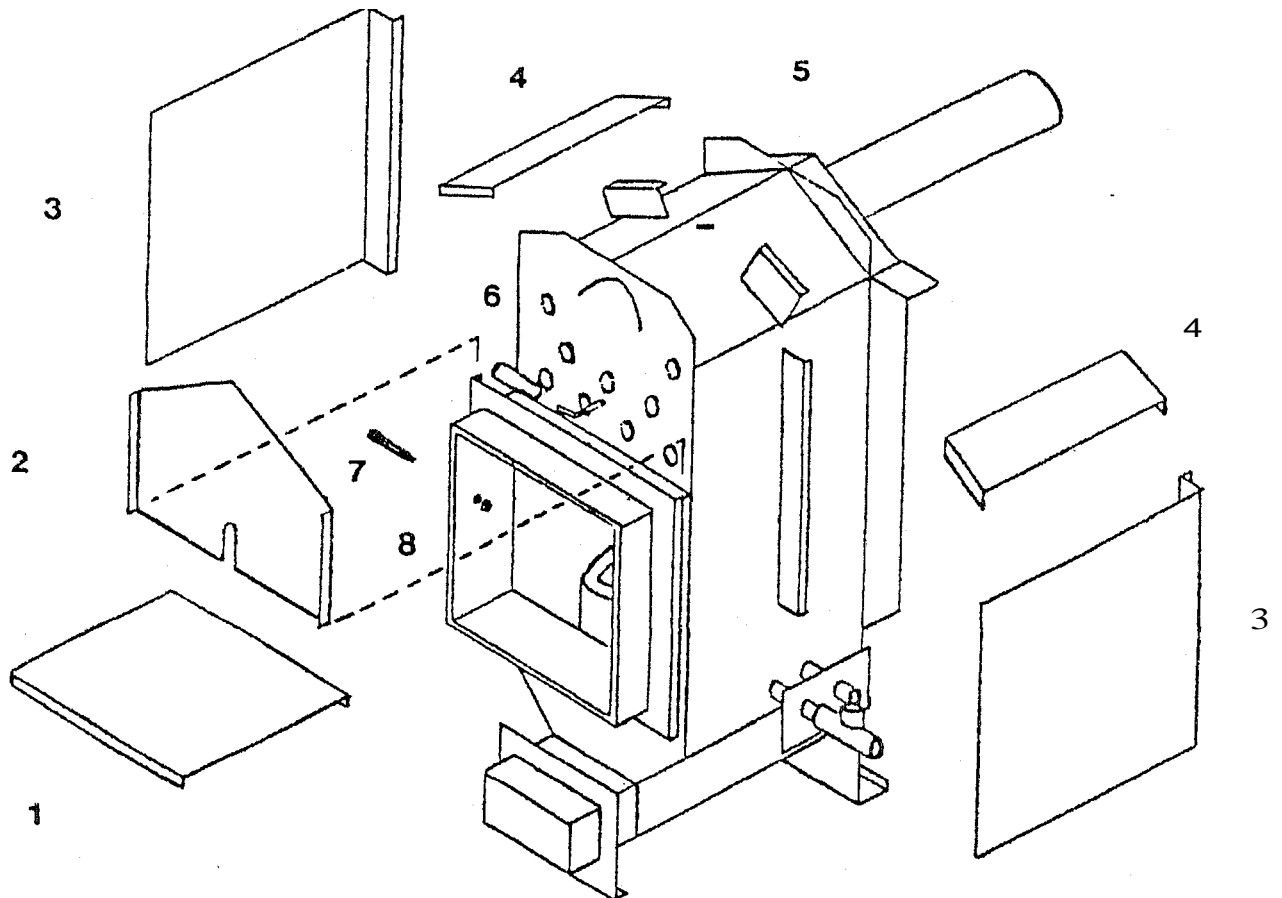

KEY#.	PART NUMBER	PART DESCRIPTION
1	5700	BURNER HEAT SHIELD
2	5680	HEAT DEFLECTOR
3	5660	SIDE HEAT SHIELD
4	5640	TOP HEAT SHIELD
5	A-5720	HEAT EXCHANGER
6	2200	WOODEN HANDLE
7	2040	5/16" x 1" SHOULDER SOLT
8	2020	1/4" NUT

Electrical

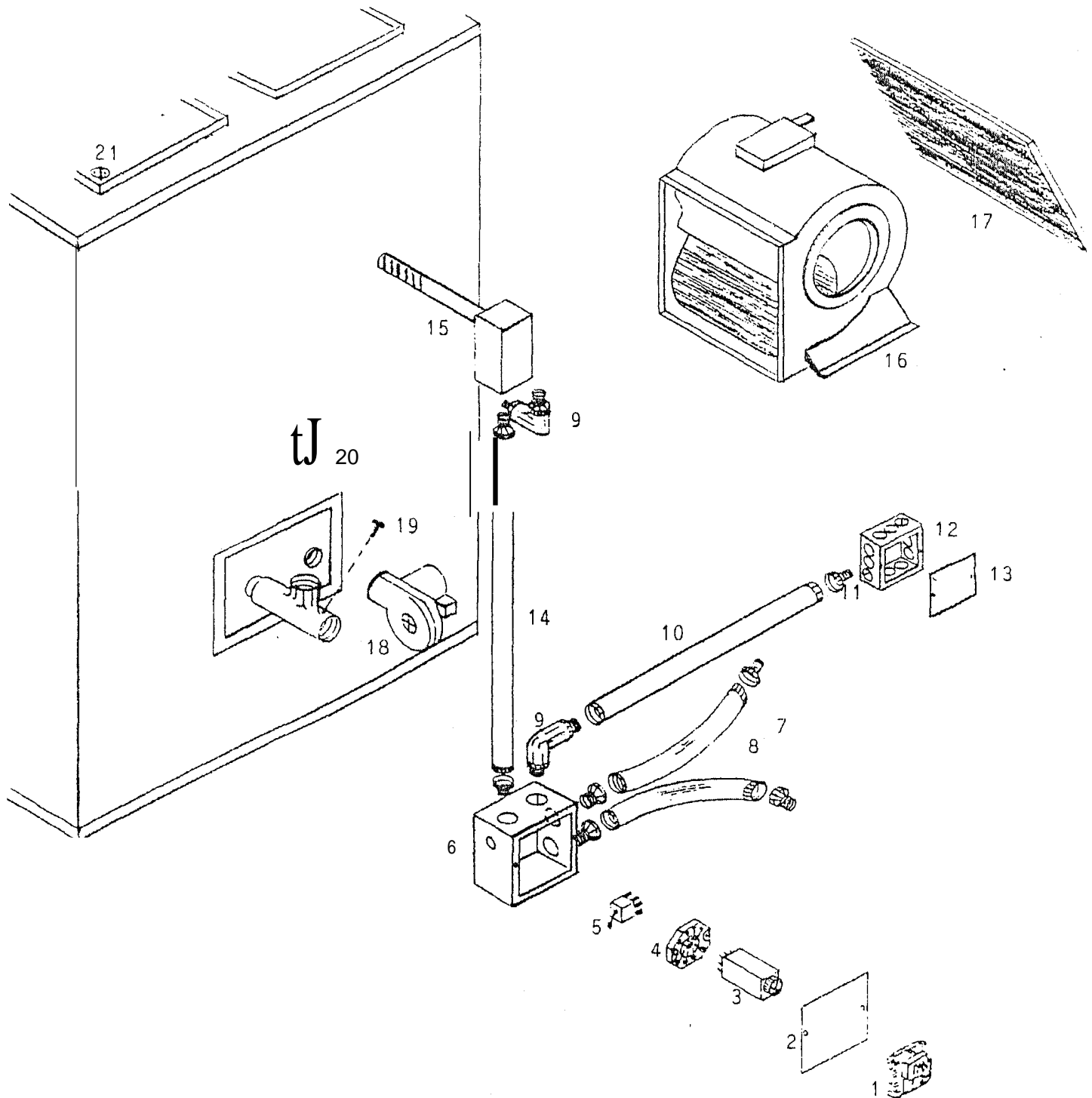

Model AH-100

REPAIR PARTS

KEY#	PART NUMBER	PART DESCRIPTION
1	1580	THERMOSTAT RELAY
2	1411	ELEC. BOX COVER, 6" X6"
3	1620	TIMER
4	1600	TIMER SOCKET
5	1680	TOGGLE SWITCH
6	1410	ELEC. BOX, 6" X6"
7	60	SEALTIGHT STRAIGHT CONNECTOR, 3/8 DIA.
	1270	EMT COMPRESSION FITTING, 90° ELBOW
	1520	FLEX CONDUIT, 3/8 DIA., 14" LONG
9		
10	1230	EMT CONDUIT, 12" LONG
11	1260	EMT STRAIGHT COMPRESSION FITTING
12	1360	JUNCTION BOX, 4" X4"
13	1400	JUNCTION BOX COVER, 4" X4"
14	1300	EMT CONDUIT, 36" LONG
15	1640	FAN LIMIT CONTROL
16	1840	COMPLETE BLOWER
17	2080	FURNACE FILTER, 20" X20" X1"
18	1860	COMBUSTION BLOWER
19	1980	1/4 X 1/2 SELF TAPPING BOLT
20	2160	FUEL DELIVERY VALVE
21	1660	LOW LIMIT SWITCH
N	1000	RED WIRE, 60" LENGTH
0	1020	BLACK WIRE, 60" LENGTH
T	1040	BLUE WIRE, 60" LENGTH
	1060	WHITE WIRE, 60" LENGTH
	1080	ORANGE WIRE, 60" LENGTH
1	1100	YELLOW WIRE, 60" LENGTH
R	1100	HIGH-TEMPERATURE BLACK WIRE, 60" LENGTH
O	1120	WIRE NUT CONNECTOR
W	1140	SPADE TERMINAL
N	1160	HIGH-TEMPERATURE SPADE

REPAIR PARTS

Model AH-170

KEY#	PART NUMBER	PART DESCRIPTION
1	A-4040	ASH PAN
2	2200	WOODEN HANDLE
3	2220	DOOR HANDLE
4	1960	5/16 X 3/8" SHOULDER BOLT
5	2000	5/16" LOCK WASHER
6	2020	1/4" NUT
7	A-4180	BURNER DOOR
8	6460	DOOR TRIM
9	6440	ASH DRAWER TRIM
10	A-6040	FURNACE FLOOR
11	6220	FRONT PANEL
12	5050170	BLOWER HOUSING
13	6280170	BLANK SIDE PANEL (LEFT OR RIGHT HANDED FURNACE)
14	6240	RIGHT SIDE PANEL (AUGER HOLE ON THE RIGHT SIDE)
15	6260170	LEFT SIDE PANEL (AUGER HOLE ON THE LEFT SIDE)
16	6160170	UPPER FURNACE TOP
17	6400	TRIM RING
18	3030170	REAR PANEL
19	6420	AUGER HOLE TRIM

REPAIR PARTS

Furnace Auger

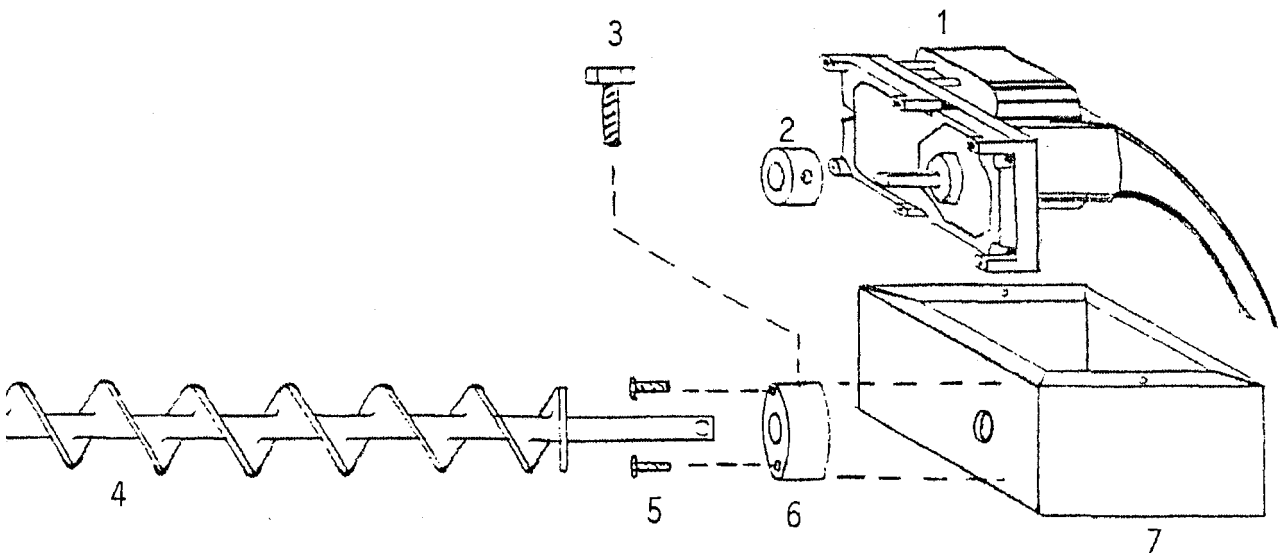

PART DESCRIPTION	
	FURNACE AUGER MOTOR
	LOCK COLLAR
	1/4 x 1/2 SELF TAPPING BOLT
	BURNER AUGER
	SHEET METAL SCREW, #10 x 1 3/4
	8-UP PORT
	6 x 6 BOX

REPAIR PARTS

Blower

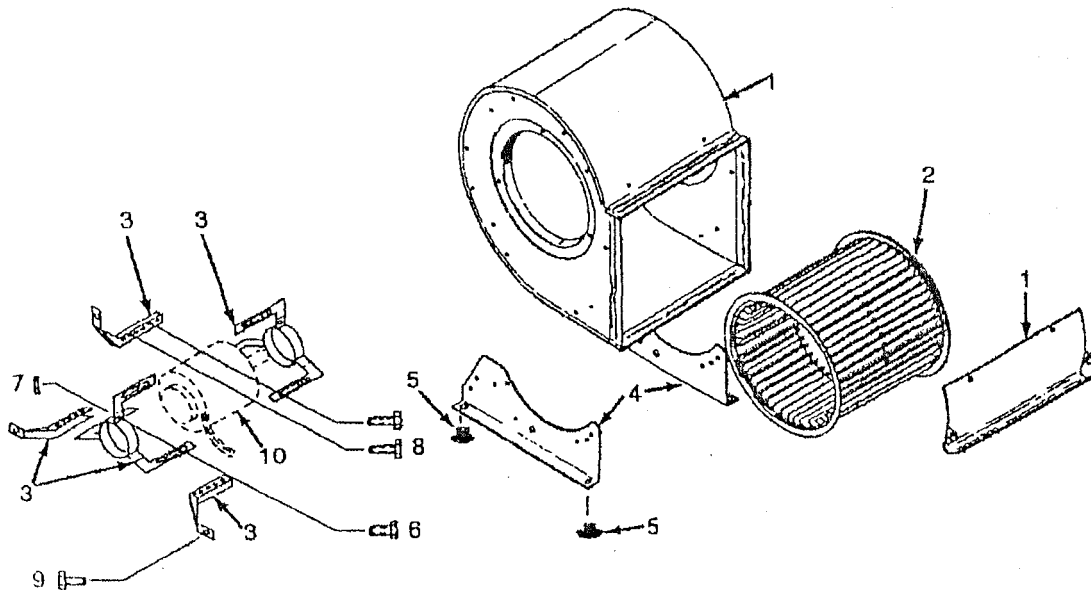

KEY#	PART NUMBER	PART DESCRIPTION
1	7F731	BLOWER, COMPLETE
2	4C710	WHEEL
3	A40152	MOTOR MOUNTING BRACKET
4	2C355	HOUSING SUPPORTS
5	8122420	VIBRATION PADS
6		HEX HD. MACH. SCREW #10-24 x 7/8"
7		NUT#10-24
8		HEXHD. THREAD CUTTING SCREW, #10- x 3 ...
9		HEX HD. THREAD CUTTING SCREW, 1/4-20 x 1/2"
10	4M098	MOTOR

BLOWER AH-170

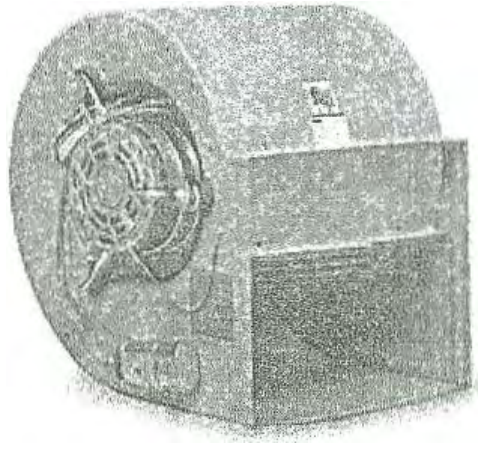

ASSEMBLED DIRECT DRIVE
FURNACE BLOWER

REPAIR PARTS

Storage Bin - Model

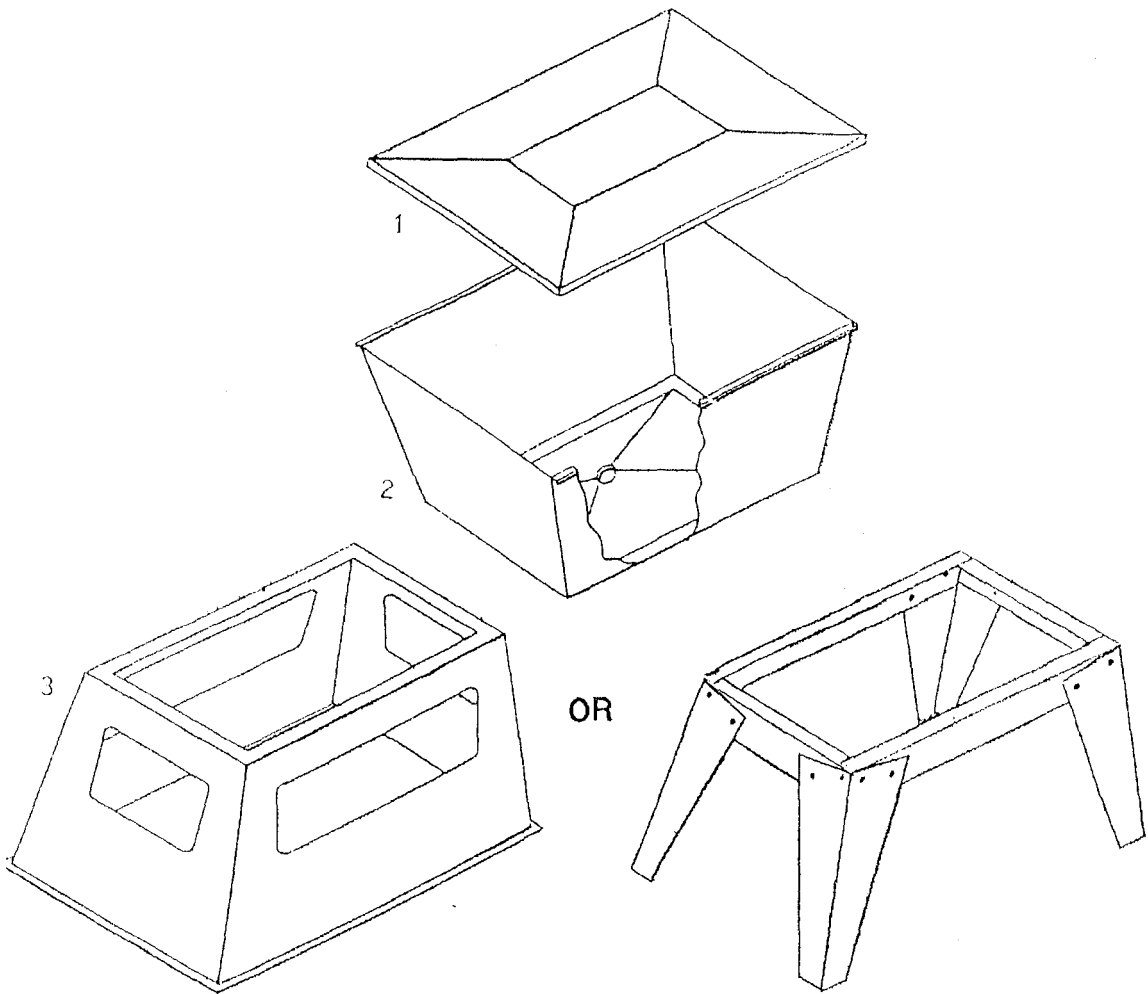

KEY#	PART NUMBER	PART DESCRIPTION
1	7520	BIN LID
2	7500	BIN CAVITY
3	7510	BIN BASE

Model AH-170 Plenum Installation

The model AH-170 can be used in conjunction with an existing furnace or as a standalone unit. If incorporating it with a return air system, a return air plenum must be built. The size of the plenum opening can be up to 21" x 21" square. Before installing the plenum, the air filters and filter rack may be removed. Notch out the area where the conduit and wiring run into the top blower housing box. Attach the plenum and install an inline filter.

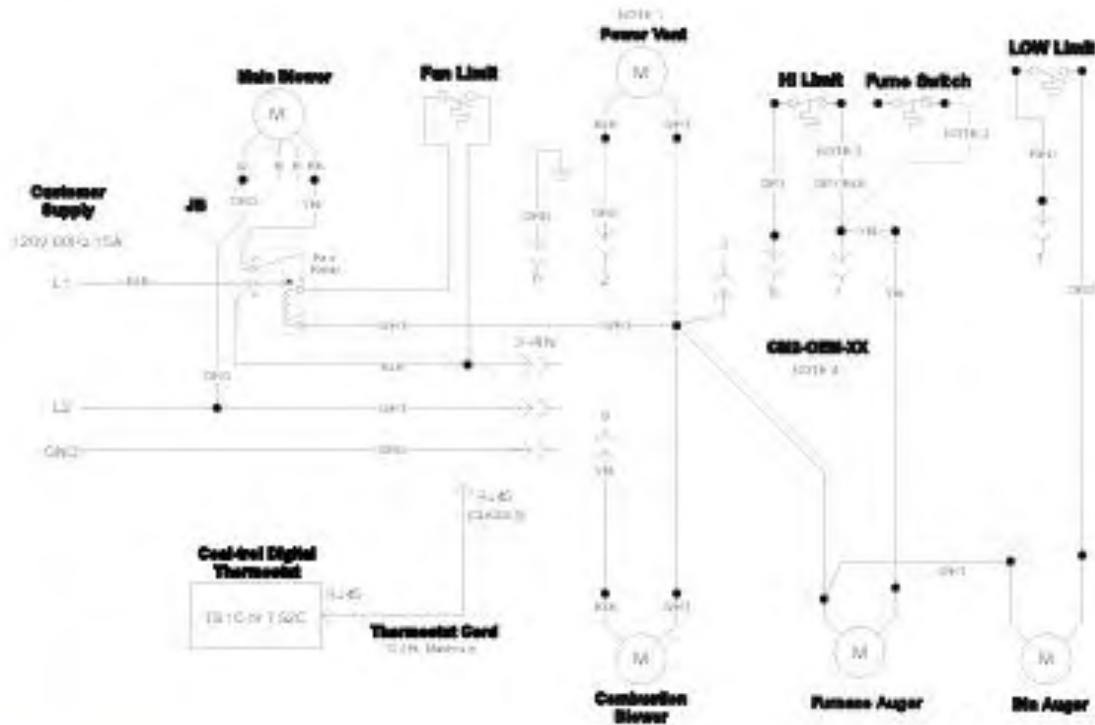

Pin	Color	Function	CMS-CBM-XX Element
1	Grey	Interlock Signal (High Limit/Fan Limit switch)	N/A
2	Yellow	Fumes Auger Motor	N/A
3	Orange	Power Vent Blower (if required)	N/A
4	White	Return	N/A
5	White	NC	N/A
6	Green	Return	N/A
7	Red	Min Auger Motor	N/A
8	Grey	Interlock Return (High Limit/return switch)	N/A
9	Blue	Combustion Blower	N/A

- NOTES
- 1) If Power vent is used, Fume switch is required.
 - 2) Return if Power vent is used.
 - 3) Interlock if Power vent is used.
 - 4) All connect or designate pins are COM2 unless noted.

CONFIDENTIAL
CONTROL FOR IMFCORN FURNACE

102811	REV 9	NUW
02/21/10	REV 8	NUW
10/1/03	REV 1	



ENCLOSED FAN RELAYS

White
Rodgers



Approximate Overall Dimensions
2 3/8" x 1 5/8" x 1 1/2"

RELAYS AND TRANSFORMERS

90-290Q THRU 90-295Q WR/RBM TYPE 84

Used for Switching Single or Two Speed Fan Motors, Solenoids, Relays, Resistive Loads and General Purpose Switching

FEATURES

- Compact, totally enclosed design.
- For heating and cooling applications and general switching.
- Quiet, reliable and economical.

SPECIFICATIONS

Temperature Range	-40°F to 150°F
Mechanical Life (no load)	1,000,000 operations, 60 operations/min.
Electrical Life (rated load)	100,000 operations, 6 operations/min. Load test making inrush rating (0.4 to 0.5 P.F.); breaking 100% continuous rating (0.64 to 0.8 P.F.)
Weight (approximate)	2.5 oz.
Agency	U.L. file number E12139 or E22381 C.S.A. file number LR13360
Coils, Frequency	50/60 Hz
Coils, Insulation	Class B
Coils, Termination	1/4" Quick Connect
Coils, Operate	85% of nominal coil voltage: 110% maximum safe operate
Coils, Duty Cycle	Continuous

SINGLE POLE NORMALLY OPEN (SPNO), SINGLE POLE DOUBLE THROW (SPDT)

Model Number		Coil Voltage AC (50/60 Hz)	Res DC OHMS	Coil Data		Inrush VA
SPNO	SPDT			Nom. Current MA	Nominal VA Sealed	
90-290Q	90-293Q	24	90	125	3	4
90-291Q	90-294Q	120	2,000	25	3	4
90-292Q	90-295Q	240	7,000	12.5	3	4

CONTACT RATING 125/250 VAC

Inductive	Resistive
8 Amps Continuous 25 Amps, Inrush	16 Amps Continuous

WIRING DIAGRAMS

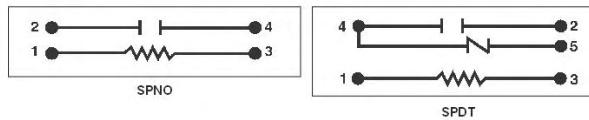



WARRANTY INFORMATION
REPLACEMENT PARTS

Corn Furnace: Model AH-100 _____ Corn
Furnace: Model AH-170 _____
Corn Boiler: Model AHB -100 _____
Corn Boiler: Model AHB -170 _____

Please enter the requested information in order to have your Part (s) processed. If part(s) are covered under warranty, please complete the form below and return this form along with the defective part within five (5) days. If defective part is not returned within the allotted time, your credit card will be charged.

Full Name of Buyer: _____

Address: _____

City: _____

State: _____

Province: _____

Zip Code: _____

Country: _____

Phone: _____

E-Mail Address: _____

Place of purchase: _____

Date of purchase: _____

Unit Serial Number: _____

Replacement Part: _____

PLEASE RETURN TO:

LMF Manufacturing
900 Park Ave
Woolrich
Lock Haven, PA
17745
Tel: 570 -769 -7775
Fax: 570 -769 -7741
www.americasheat.com
lmf@americasheat.com