



# DS Greenhouse Blast

High Efficiency Wood or Coal Green House Furnace

Model: GH450

## OWNER'S MANUAL



MADE IN USA  
By  
D.S. MACHINE SHOP

**Before you install or operate a DS Furnace, you must:**

- Read all instructions carefully
- Install smoke and carbon monoxide detectors.

# ALL D.S. Furnaces must be installed by a NFI Certified Technician

## Safety Instructions

1. Read all instructions before installing or operating any DS furnace
2. You must install smoke and carbon monoxide detectors before you install or operate any furnace. **Check your local codes, this installation must meet their rulings.**
3. Do not open bottom ash door to increase draft. It is designed only to empty ash pan.
4. Never leave furnace doors open when furnace is unattended.
5. Install barometric or manual damper when burning coal.
6. Do not use a manual, barometric or automatic damper when burning wood.
7. Do not hook up a wood or coal furnace to an aluminum Type B gas vent. Use a code approved Class A chimney. A minimum of 20' high.
8. On all new installs connecting to an existing chimney, a level 2 chimney inspection must be done by a Certified Chimney Sweep.
9. Clean chimney before installing furnace. If there is creosote attached to the liner you could create a serious chimney fire.
10. Never leave children unsupervised when they are in same room as furnace. Provide a sturdy barrier to keep children and pets a safe distance from the furnace, or they could get burned.
11. Keep Furnace area clear from all combustible materials, gasoline, and other flammable vapors and liquids.
12. Furnace must be installed on a noncombustible floor.
13. Check the clearance to combustible walls and floors on page 4.
14. Do not allow anyone who is unfamiliar with furnace to operate it.
15. Spend some time with your furnace to become well acquainted with the different settings and how each setting will affect its burning patterns. It is impossible to state how each setting will affect your furnace.
16. Be extremely careful when removing the furnace ash pan. **It may be very hot!**
17. Make sure your single wall chimney connectors have at least 3 screws per joint.
18. Do not install this furnace in a mobile home or trailer.

## Operational / Work Practice Standards

1. When burning wood, burn only seasoned, dry cord-wood that has been dried; then warmed before firing. (Warming cord-wood means placing in a heated building for 1 day before burning)
2. Keep wood under cover: in a wood shed, or a tarp.
3. Right after delivery: stack cord-wood under cover
4. Split cord wood before drying.
5. Do not burn green wood, it needs to have no more than 20% moisture.
6. All firewood must be seasoned at least 1 year.
7. Check cord-wood with moisture meter. Check wood moisture at least once a week!
8. Keep a 2" to 3" ash layer on top of your grates when burning wood. Note: Do not cover louvers.
9. The furnace is designed to burn air dried wood and coal at a predetermined firing rate. Over firing occurs when the ash door is left open during operation or a highly volatile fuel, i.e. large amounts of small kindling is used. Do not exceed 600 degrees on top of furnace.
10. When tending the firebox always open load door slowly to minimize smoke out the fire door or to avoid a "flash back".
11. Check the fit on the load door. It must fit tightly. If it does not, check for deterioration or wear of the ceramic rope seal. Replace defective seals.
12. Inspect and clean your chimney and single wall chimney connectors regularly.
13. In the event of a chimney fire, shut all draft controls and blower off and call your fire department immediately. Alert everyone in the house. If flue is still burning vigorously, throw baking soda into firebox or discharge a fire extinguisher into fire box. After the chimney fire is over, have a certified chimney sweep complete a level 2 chimney inspection, before farther use of your chimney.
14. Equip your building with fire extinguishers, carbon monoxide and smoke detectors.
15. Do not burn garage, gasoline or any other flammable liquids in this furnace.
16. This is a wood and coal-burning furnace and should not be altered in any way.
17. Do not burn furnace over 600 degrees or warranty will be void!

18. When used in a large greenhouse and they are forecasting a cold night it is advisable to load and fire your furnace at 3 to 4 o'clock in the afternoon so that you do not fall behind. If you wait till the sun sets to fire your furnace you may be playing catch up all night. In the morning when it is cold with a sunny day in the forecast you may want to consider shutting the furnace down at 5 o'clock in the morning so that when the sun comes out and it warms up so that there's not too much heat in your green house till the furnace fire dies down.

**Note:** When burning coal, shake ashes every 12 hours if possible. You must keep your ashes cleaned out from under grating. This may require emptying your ash pan daily. If there is no air space under the grates, the grates will warp and become inoperable.

## Starting A Coal Fire

Fully open Hot-Air Regulator. Place crumpled paper and kindling wood on grate and ignite with match or lighter. Use a good amount of kindling to get the fire started. Add larger pieces of wood to get a hot fire. Once you have a hot fire, add 2" of coal over the entire grate area. As the coal starts burning and glowing red add another layer of coal.

Keep adding coal until you have an 8" body of fire. You can now add 50 lbs. of coal, adjust draft on Hot-Air Regulator to meet your needs. **NOTE:** You can also use charcoal briquettes for a fire starter.

With new steel there is a small amount of oil or dirt on the metal. You may smell an odor. This is normal during the first operation. You may want to assemble the furnace out of doors and build a small fire in it to "BURN OFF" this dirt and oil before installing unit.

## Starting A Wood Fire

When starting a wood fire use the same steps as starting a coal fire above, but do not add coal. Allow ash to build up on top of grates, this will not choke fire until it covers louvers. For most efficient burn, keep approximately 2" to 3" of ash on grates at all times.

With new steel there is a small amount of oil or dirt on the metal. You may smell an odor. This is normal during the first operation. You may want to assemble the furnace out of doors and build a small fire in it to "BURN OFF" this dirt and oil before installing unit.

## Creosote – Formation and need for removal

When wood is burned slowly, it can produce tar or other organic vapors, which combined with expelled moisture will form creosote. The creosote vapors condense in the relatively cool chimney flue of a slow burning fire. As a result, creosote residue accumulates on the flue lining. When ignited, this creosote makes an extremely hot fire. The chimney connector and chimney should be inspected at least twice monthly during the heating season to determine if a creosote build-up has occurred. If creosote has accumulated, it should be removed to reduce the risk of a chimney fire.

**NOTE:** Firewood must be seasoned for one year. That means cut, split and stacked under shelter with sides open so the wind can dry it. Wood needs to have no more than 20% moisture. Stack indoors 1 day prior to burning. Do not shut primary air supply or it will smolder fire and create creosote.

# Locating Furnace

1. The furnace must be located on a noncombustible floor
2. For greenhouse installation it is recommended to locate furnace on the naturally coldest end of greenhouse. (north or west) If greenhouse is sloped, place furnace at lowest end of greenhouse. Installing an air tunnel with a fan is the optimal way to circulate air. Any horizontal or ceiling fans will help. When fans are not an option try installing 2 pieces of tin on top of furnace. Start up 16" from back top edge of furnace and run 16' of tin, 2 pieces wide, up into the peak of the greenhouse. This will help start your natural circulation. See drawing below.

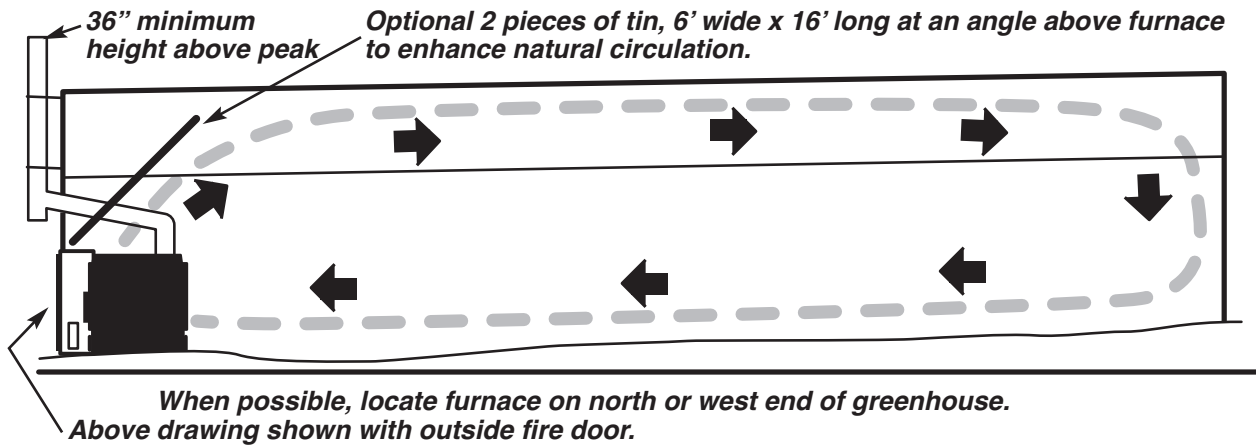

3. For building installation. It is recommended that the furnace be centrally located in the building in such a way that air can naturally circulate around furnace and around the whole building. If this is not an option it is recommended to install fans to circulate the air. See drawing on page 5.

4. You must follow all clearance to combustibles.

5. Connection of the furnace to the chimney should be made as directly as possible (6 feet maximum horizontal) and not more than two bends, when needed, should be used. No reduction in flue pipe below 10 inches in diameter should be used. The single wall chimney connector connecting the furnace to the chimney should be at least 24 gauge. Thicker gauges are available and will resist corrosion longer and need fewer replacements. Slope the flue pipe back towards the furnace, 1/4" per foot of horizontal run. That way if any condensation forms in the pipe it will be carried back into the furnace. The connector pipe should be installed so that the upper pipe section fits inside the lower section. This way any condensation building up inside the pipe will stay inside the pipe as it flows down the inside surface. Horizontal pipe runs should have the pipe seams turned up. Particular attention should be paid to the point where the flue passes through a wall or ceiling. This penetration should always be made with a thimble, insulated pipe, and then proper accessories following manufacturers instructions. Chimney connectors must not pass through the ceiling, concealed spaces, or enter the chimney in the attic, unless proper clearance or insulated pipe is used following manufacturers instructions. **REMEMBER** that all single wall chimney connectors should be connected with at least 3 sheet metal screws per joint. A fire in the stack may cause vibration and poorly fastened single wall chimney connectors may come apart causing an extreme fire and smoke hazard. Do not extend single wall chimney connector past the inside edge of the flue liner. If you have a manufactured Stainless Steel chimney, attach single wall chimney connectors to single wall chimney connector adapter. Where the single wall chimney connector connects to a masonry chimney, the flue to the chimney should be larger than the stove single wall chimney connector so you can insert the single wall chimney connector out to the inside edge of the chimney, but not past.

<b>Clearance to Combustible Chart</b>		
<b>Caution: Do NOT store combustible or flammable material near stove</b>		
	<b>Specifications</b>	<b>GH450</b>
<p>10" Exhaust</p>	Sides	36"
	Back	36"
	Front	60"
	Top	56"
	Clearance from flue to combustible with single wall stove pipe	18"
	Clearance from flue to combustible with double wall stove pipe	6"
	Corner clearance from stove to combustible	36"

Then seal as tight as possible and cover with a trim collar.

6. The furnace must have its own flue. Do not connect this unit to a chimney flue serving another appliance.
7. The masonry chimney should not have any missing mortar or loose bricks.
8. There should be no mortar or parts of the chimney blocking the chimney flue.
9. There should be a two inch clearance between any chimney except chimtek has zero clearance.
10. The chimney should extend at least 2' above the highest point of the house, or 2' above the point at which the chimney is 10' from the roof.

## Chimney Requirements

The minimum height of a chimney system for the D.S. Furnace is 20 feet. The chimney must exceed the roof of a house at a minimum of 3 feet at any point of exit. In a pitched roof installation the chimney must be 2 feet higher than anything within a 10 foot radius of the chimney. It is important to have a chimney draft of 0.06 water column. It is required to abide by the manufacturer's instructions on Class A chimneys as well as local building codes. It is not recommended to build a chimney on an addition that is lower than the main part of your house. Do Not extend the single wall chimney connector past the inside of a masonry chimney liner. Never connect this unit to a chimney serving another appliance. Should you have a problem with inadequate draft you should see page 11.

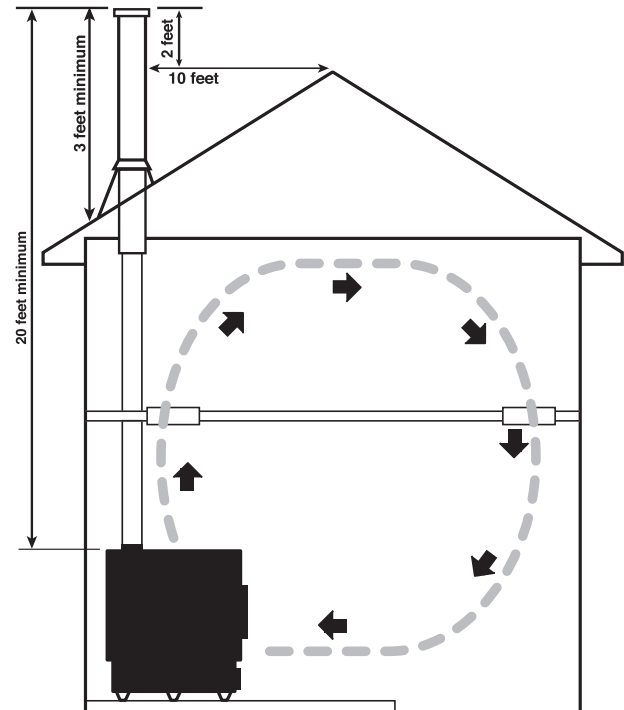

# Thermostat Hook-Up for GH Blast

- Mount Thermostat to wall
- Mount Relay to wall
- Mount Limit Switch on side of furnace
- Connect wiring as per diagram

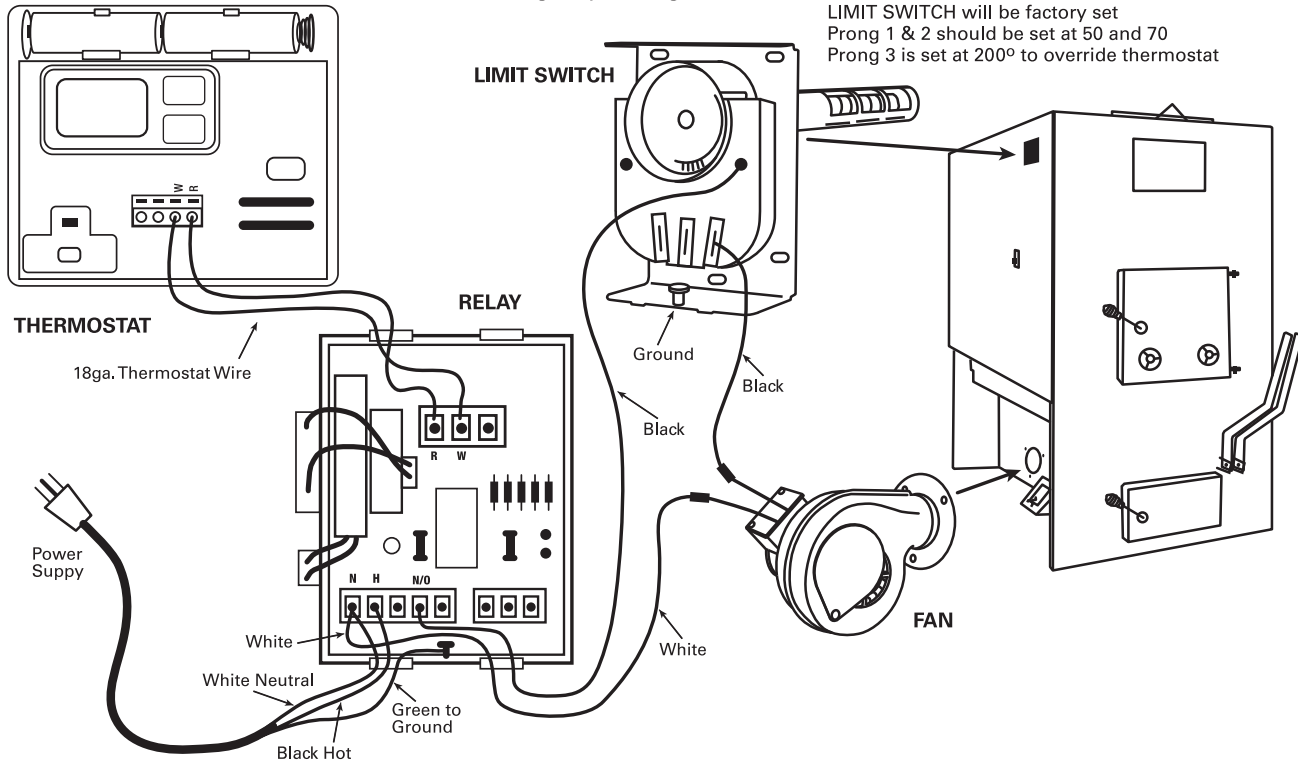

# DS Pneumatic Powered Thermostat Kit

This thermostat is designed for use with a wood or coal furnace only. It will not take the place of proper furnace management. You will get the best response from this unit if you service your furnace according to the manufacturer's recommended practices, **Your Air Supply needs to be clean and dry.**

## Installation Instructions

A - Install cylinder approx. 24" above and center of draft inlet lid with #14 x 3/4 self drilling screws. Fasten chain with no slack when cylinder is extracted.

B - Mount air regulator and thermostat 50 – 70 feet from furnace.

C - Connect 5/32 air hose from regulator to "in" on thermostat. Then from "out" of thermostat to cylinder at furnace as per diagram. Air regulator needs to be set at 20psi.

D - Test the unit after installed to make sure draft lid **opens** and **closes** properly. Then build your fire in furnace, and set thermostat to desired temperature.

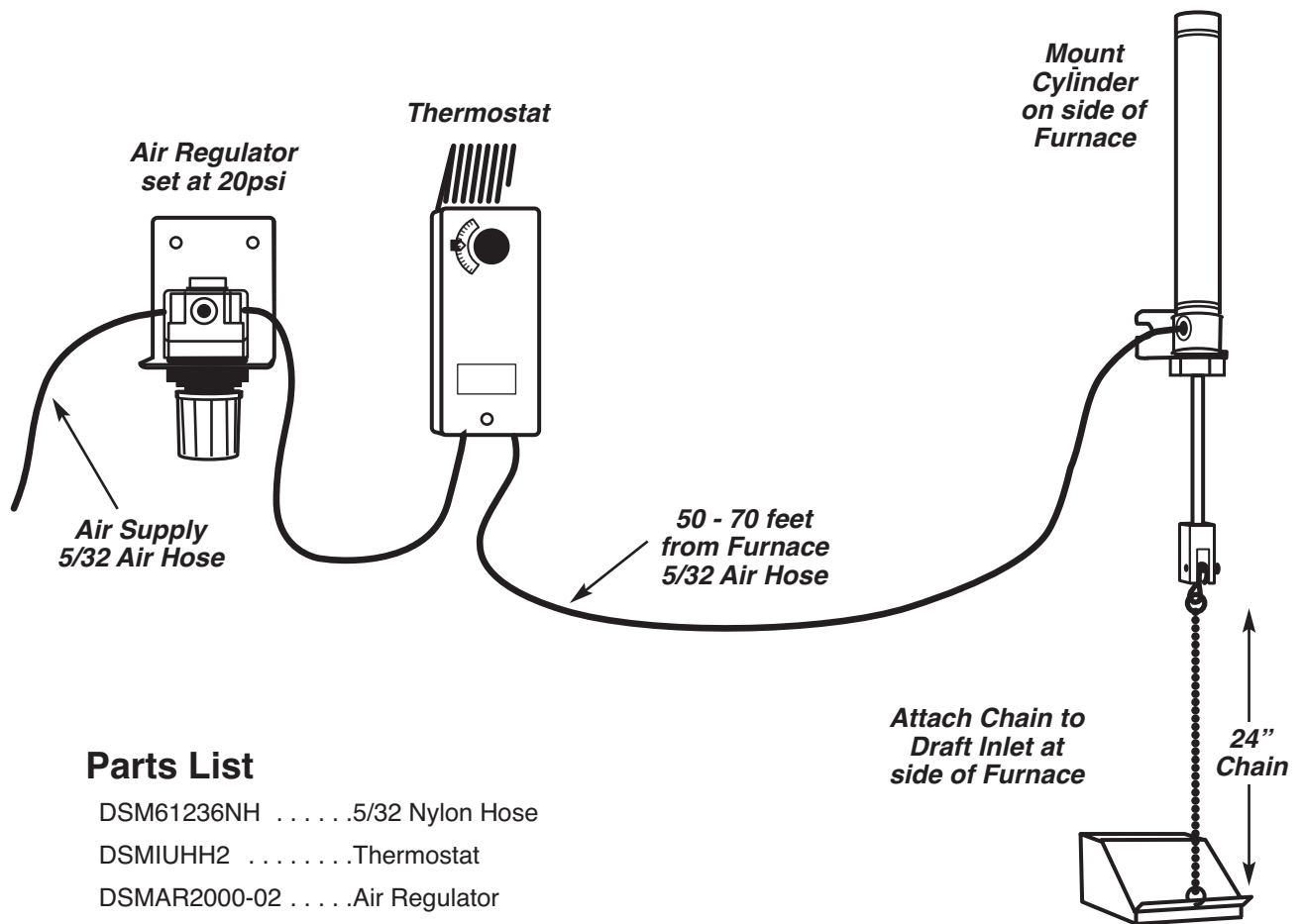

## Parts List

DSM61236NH	.....	.5/32 Nylon Hose
DSMIUHH2	.....	Thermostat
DSMAR2000-02	....	Air Regulator
DSMK4515	.....	Gauge for Air Regulator
DSM75RSR	.....	Cylinder
DSMCLEVISKIT	....	Clevis Kit for Cylinder
DSMMOUNTBKT	...	Mount for Cylinder
DSMCYLFITTING	...	Push-Lok fitting for Cylinder

# Outside Fire Door Option (O.F.D.)

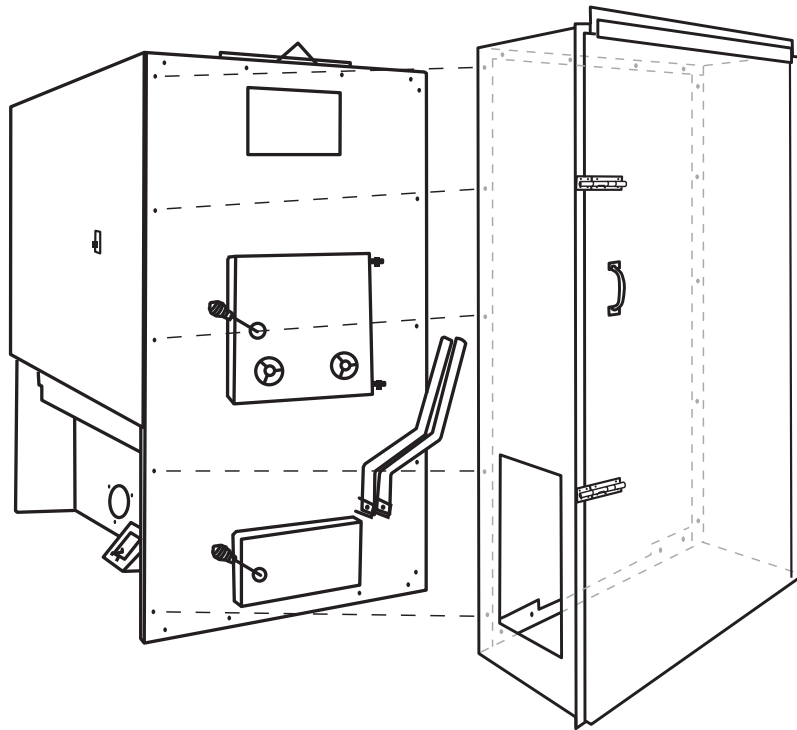

*Use 18 - #14 x 3/4 self tapping screws to attach O.F.D. to front of furnace.*

**WARNING:** When fastening combustible greenhouse wall framing to O.F.D. flange, keep all combustible material at least 1" away from main frame of O.F.D.

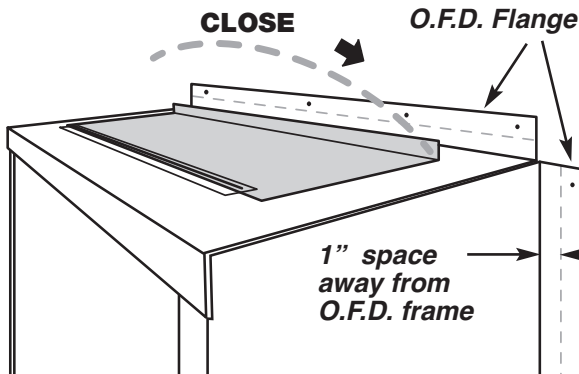

## INSTALLATION INSTRUCTIONS:

Install O.F.D. on GH 450 Furnace. See drawing above. Install the GH 450 Furnace with the O.F.D. already installed, into the wall of your greenhouse. With the GH 450 Furnace and Optional O.F.D. in final position, frame wall of greenhouse to within 1" of O.F.D. frame.

**WARNING:** Keep all combustible materials 1" away from O.F.D. frame. Approximate rough opening will be 41-3/4" wide x 74-3/4" high.

**NOTE:** CLOSE top vent door while loading furnace to keep smoke & gases out of greenhouse while loading furnace. Reopen top vent door before closing O.F.D.

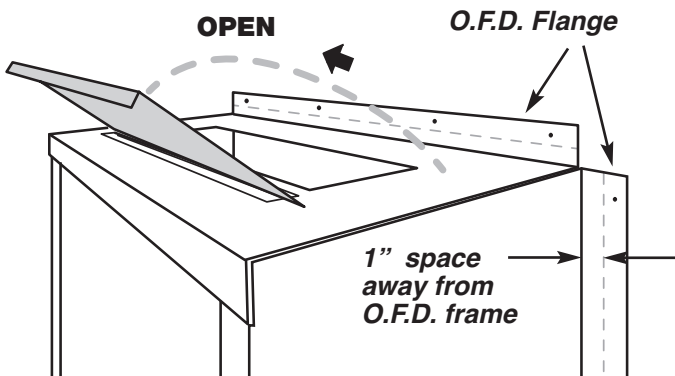

**WARNING:** Top vent door must be OPEN when O.F.D. is closed to allow air circulation around front of furnace.

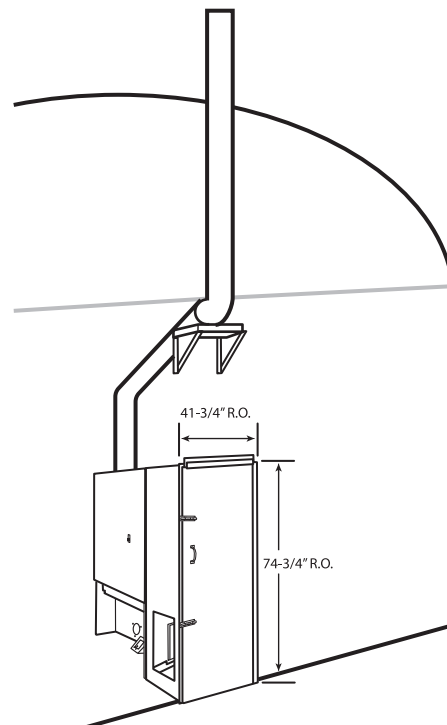



# Firebrick Panels for GH 450

ALL Fire Brick are 2-1/2 x 4-1/2 x 9 unless noted otherwise.

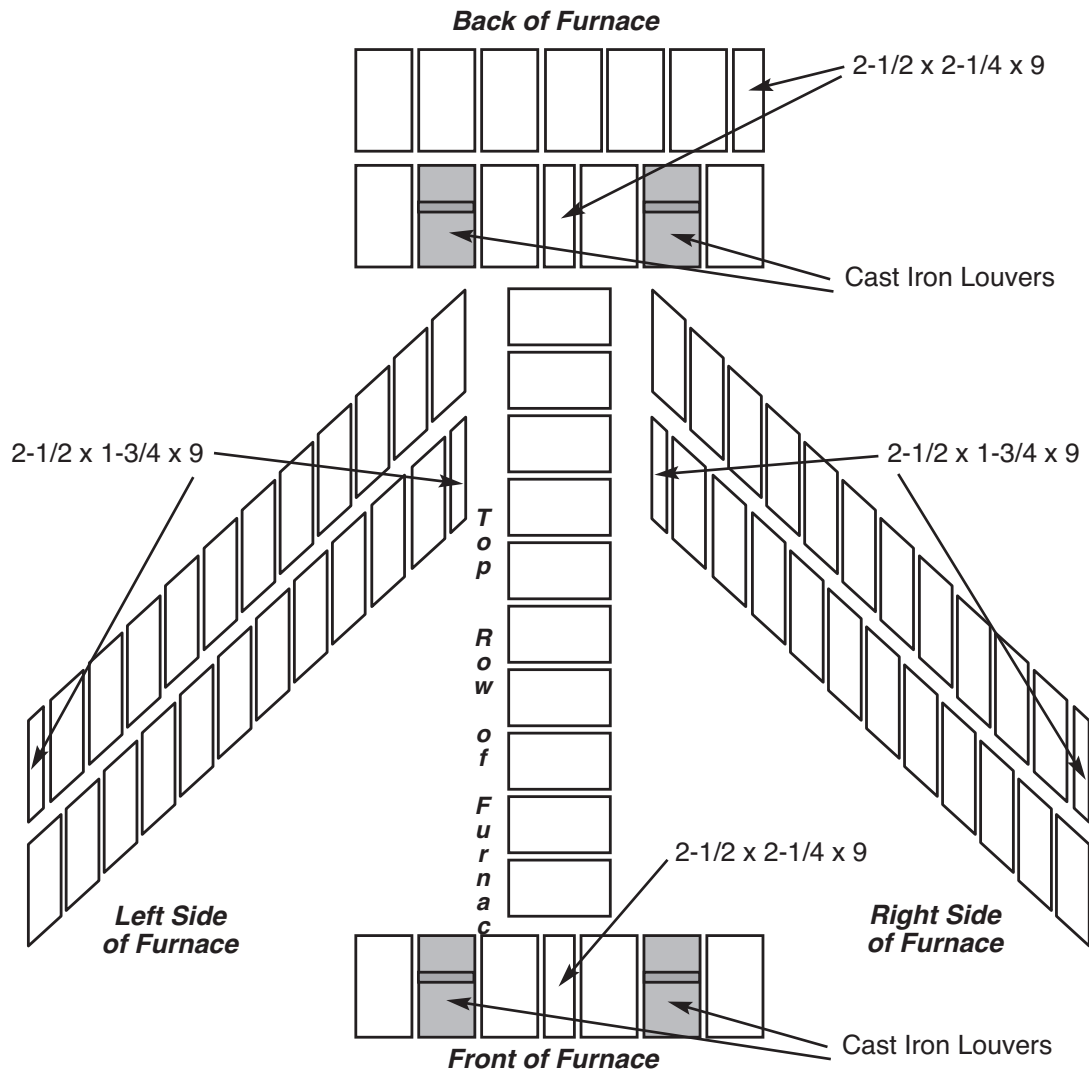

## GH 450 Firebrick Set

Front	..... 4	.. 2-1/2 x 4-1/2 x 9
Front	..... 1	.. 2-1/2 x 2-1/4 x 9
Back	..... 10	.. 2-1/2 x 4-1/2 x 9
Back	..... 2	.. 2-1/2 x 2-1/4 x 9
Right Side	... 22	.. 2-1/2 x 4-1/2 x 9
Right Side	... 2	.. 2-1/2 x 1-3/4 x 9
Left Side	... 22	.. 2-1/2 x 4-1/2 x 9
Left Side	... 2	.. 2-1/2 x 1-3/4 x 9
TOTAL	..... 58	.. 2-1/2 x 4-1/2 x 9
	3	.. 2-1/2 x 2-1/4 x 9
	4	.. 2-1/2 x 1-3/4 x 9

# Parts List - Green House Blast 450

Qty per Furnace	Description	Model	Parts#
1	Left side sheet metal jacket	.450	450-LHSM
1	Right side sheet metal jacket	.450	450-RHSM
1	Back sheet metal	.450	450-BSM
2	Cast Iron 3-Grate Rail for 6" Grate	.450	63-GR
2	Cast Iron 4-Grate Rail for 6" Grate	.450	64-GR
7	Cast Iron 6 x 21 Grates	.450	6x21 CIG
1	18 X 18 Fire Door	.450	18-FD
2	Cast Iron Ash Door	.450	ASH6-D
2	Spinners on Fire Door	.450	4-SPOB
2	1/2" Spring Handle on Ash Doors	.450	12-CSH
1	5/8" Spring Handle on Fire Door	.450	58-CSH
1	Ash Pan 15-1/2"w x 26"d x 6"h	.450	155-26-6AP
1	Ash Pan 15-1/2"w x 28"d x 6"h	.450	155-28-6AP
1	Back Ash Shaker Bar Assembly	.450	160-BASBA
1	Front Ash Shaker Bar Assembly	.450	160-FASBA
4	Cast Iron Louvers	.450	CI-FL
1	Top Door Gasket 3/4" Round x 6'	.450	3496-kit
2	Bottom Door Gasket 5/8" Round x 54"	.450	5854-kit
1	Hot Air Regulator 450 Hot-A-Reg	.450	Hot-A-Reg

# Trouble Shooting

## 1. Problem:

Smoke puffs from furnace

### **Solution:**

Check chimney draft. Check for blocked chimney or flue pipe. Use mirror to check chimney clearance.

Check ash pit – if it is too full, empty.

Make sure furnace room is not too airtight.

Make sure all of chimney mortar connections are airtight,

Check ash drawer. Make sure it's airtight.

Check chimney for possible down-draft caused by taller surrounding trees or objects. Correct with proper chimney vent cap.

Check the possibility of a cold chimney forcing cool gases backward. Remedied by properly insulating chimney with non-combustible liner – non combustible insulation.

Fuel may be too green.

Make sure no other fuel burning devices are connected to the chimney impairing the draft.

Check chimney draft, it should be .06 inches of water column. This service is provided by a certified chimney sweep.

If bottom door is open it can create more draft than what chimney can handle. Therefore it can smoke out out the fire door when open.

Are chimney and single wall chimney connector the same size or larger than exhaust outlet on furnace? No reduction should be made from furnace exhaust outlet to chimney.

## 2. Problem:

Inadequate heat being delivered to your building.

### **Solution:**

Check building insulation – is it adequate?

For greenhouse install fans or for natural circulation in stall two pieces of tin. See page 4.

Your wood fuel may be too low grade. Hardwoods are recommended.

If furnace room is warm but your building isn't, put vents in floor or walls to circulate heat. Maybe add fans.

Is furnace the recommended BTU size for your building?

If you have a Hot-Air Regulator set at high and furnace does not heat properly, shorten chain one or more notches. Do not exceed 600 degrees on top of furnace. Overheating will damage furnace.

Use seasoned wood ONLY. Wet wood robs the energy that normally distributes through the building.

Recommended 20% or less moisture.

## 3. Problem:

Excess smoke or flames coming out door when refueling

### **Solution:**

Wait 15 seconds and open door SLOWLY – then refuel.

Check length of flue pipe to chimney. Your unit should be within six (6) feet of your chimney.

Make sure chimney cap is not too close to the top of the chimney.

Check chimney draft – make sure chimney flue pipe is clean and chimney is of adequate height.

Make sure you're not suffocating the fire with excessive amounts of unburned coal or wood.

NOTE: If you open fire door shortly after loading wood, it will smoke.

Are chimney and single wall chimney connector the same size or larger than exhaust outlet on furnace? No reduction should be made from furnace exhaust outlet to chimney.

## 4. Problem:

Odor from first fire

### **Solution:**

The odor from new steel should disappear in a few hours if burning hot.

If the odor remains, call your dealer immediately. A bad weld can cause a fume leak.

## 5. Problem:

Excessive Creosote

### **Solution:**

Check the grade of wood you are burning. Does it have 20% or less moisture.

Make sure your unit is serviced by its own proper chimney.

Check length of flue pipe and its connections. Maximum length of 6 feet horizontal run and 2 elbows.

Make sure you are burning the smallest, hottest fire to adequately heat your area.

Also see Solutions to Problem One.

Stack wood indoors for 1 day prior to burning.

All fire wood must be seasoned for 1 year.

# Limited Warranty



## LIMITED WARRANTY Greenhouse Blast GH 450

### **Please read this warranty carefully!**

D.S. Stoves warrants this Greenhouse Furnace against premature failure of any component due to workmanship, quality or materials. So long as it is owned by the original purchaser, subject to terms, limitations and conditions herein set out. **Soft coal is prohibited in any DS Furnace or Boiler. This warranty is void if anything other than hard coal or dry cord wood is burned in this unit.**

	<b>Time Period</b>
1 - Firebox	Five Years
2 - All doors - (fire and ash door)	Five Years
3 - Cast Iron Components (grates, grate rails)	Five Years
4 - All Electrical Components	One Year

D.S. Stoves will replace, at no charge to the owner, any defective part which D.S. Stoves determines affects the operation of the furnace.

The owner is responsible for labor and costs to complete the repair. The owner may at his option and with D.S. Stoves approval, have the furnace shipped to the factory for repair. All labor and material costs for repair at the factory will be borne by D.S. Stoves.

The owner is responsible for all shipping costs.

D.S. Stoves gaskets, paint or enameled parts, firebrick, and furnace cement are not covered by this Limited Warranty.

Failure to follow installation and basic operation recommendations written in this negligence abuse modifications to the furnace or over firing 600 degrees F maximum, as determined by D.S. Stoves or its authorized dealers.

This Limited Warranty is in lieu of all other warranties either expressed or implied.

D.S. Stoves is not responsible for accidents due to improper installation or failure to follow instructions.

– D.S. Stoves  
238-B Old Leacock Road  
Gordonville, PA 17529  
717-768-3853